

CHAPTER – 12

ELECTRICITY

Think life without “electricity” in this modern society. Is it possible to survive without electrical energy in world of technology. Since we are science student, so it is necessary to understand the basic concept behind the word “electricity”

Charge (q)

It is a very small particles present in an atom it can be either negative (electron) or positive (proton)

“Coulomb” is the SI unit of charge, represented by C.

Net charge (Q)– Total charge

IC Net charge is equivalent to the charge contained in nearly electrons 6×10^{18}

$$Q = ne \quad (\text{n is no: of electron})$$

If $Q = 1\text{C}$, $e = 1.6 \times 10^{-19}\text{C}$ (negative charge on electron)

$$n = \frac{Q}{e} = \frac{1}{1.6 \times 10^{-19}}$$
$$= \frac{100}{16} \times 10^{18} = 6.2 \times 10^{18}$$

$$n = 6 \times 10^{18} \text{ electron}$$

Current (I)

Rate of flow of net charge is called current. Denoted by (I)

$$I = \frac{Q}{t} \quad \text{t is time}$$

SI unit of current is “Ampere” rep. by A.

Ampere Defined as one coulomb of charge following per second.

$$1\text{A} = \frac{1\text{C}}{1\text{s}}$$

In an electric circuit the electric current flow in the opposite direction of the flow of electron (–ve charge) conventionally. It flows from the +ve terminal of battery or cell to –ve terminal.

Small quantity of current are expressed in

$$\text{mA (milli Ampere)} = 10^{-3} \text{ A}$$

$$\text{uA (micro Ampere)} = 10^{-6} \text{ A}$$

Ammeter– It is an instrument used to measure the electric current in a circuit.

It is always connected in series in a circuit

It is represented by the symbol $\text{---}^+ \text{ (A) } \text{---}$ in an electric circuit. It has low resistance.

Electric Circuit– It is a closed path along which an electric current flow.

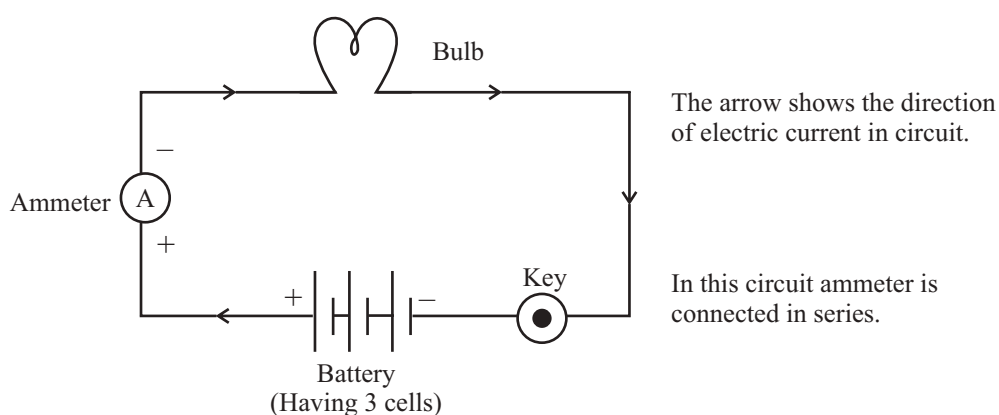

The electron can only flow when there is difference of electric pressure. For example “water flowing through a tube” It is only possible when there high pressure at one side and low at another side, then it will move from high pressure to low pressure.

In case of electric current, the flow of charge is made possible due to chemical action with in a cell that generates the potential difference across the terminals of the cell.

8. Electric potential Difference– It is defined as the work done in carrying a unit charge from one point to another between the two points of an electric circuits.

$$V = \frac{W}{Q}$$

V – Potential Difference

W – Work

Q – Net Charge







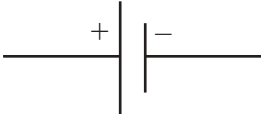

SI unit of potential difference – Volts rep. by “V”

One Volt When 1 Joule of work is done to carry one coulomb (1C) of charge from one point to another of a current carrying conductor then the potential difference is said to be 1V.

$$1V = \frac{1J}{1C}$$

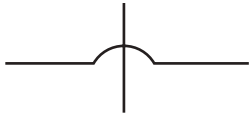
Voltmeter It is an instrument, used to measure the potential difference and represented by the symbol $\text{---}^+\text{V}\text{---}$ in an electric circuit. It is always connected in parallel across the points between which the potential difference is to be measured. It has high resistance.

Symbols for some commonly used instrument in circuit diagrams

- (1) Cell 
- (2) Battery 
- (3) Key (switch) open 
- (4) Key (Close) 
- (5) Joint wire 
- (6) Wires with no join 
- (7) Bulb 
- (8) Ammeter 
- (9) Voltmeter 

Georg Simon Ohm (physicist) 1787 – 1854

Found the relationship between the current (I) flowing through a conductor and potential difference (V) across the terminals of a conductor using the circuit diagram.

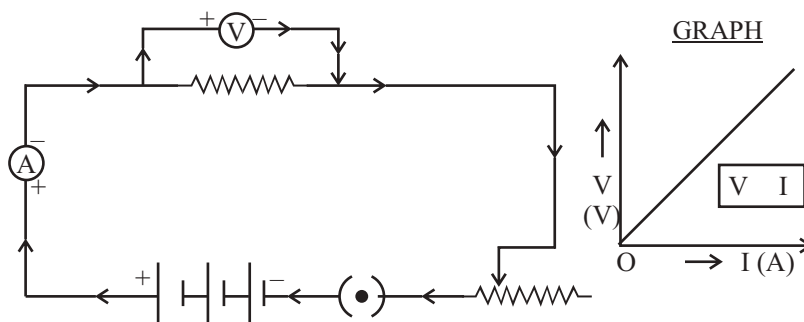

In this circuit diagram we come across two new symbols

RESISTANCE (R)
 OR RHEOSTAT (Variable Resistance)

Ohm’s Law He stated that the electric current flowing through a conductor is directly proportion at to the potential difference across its ends, provided the temperature remain constant

$$\frac{V}{I} = R$$

Where “R” is the proportionality constant for the given metal at given temperature and is said to be resistance, the graph between V and I is always straight line.

Resistance– It is the property of a conductor that opposes the flow of current. It is represented by ‘R’ and symbol is

SI unit of resistance “Ohm” OR

1 Ohm – The resistance of a conductor is said to be one Ohm, when the potential difference across the conductor is 1V and the current flowing through it is 1A.

$$V = IR$$

$$R = \frac{V}{I}$$

$$1 \text{ Ohm or } 1 = \frac{1V}{1A}$$

Rheostat–

As we know that

$$V = IR$$

$$I = \frac{V}{R} \quad \left\{ \begin{array}{l} \text{Shows that current through} \\ \text{conductor resistor is inversely} \\ \text{proportional to its resistance} \end{array} \right\}$$

So to increase or decrease the current accordingly in the circuit a component is used is called “Rheostat”, that regulates the current without changing potential difference. Represented by “Rh”

Its symbol is  OR 

if a conductor has less Resistance, then more current will flow through it.

FACTORS ON WHICH RESISTANCE OF A CONDUCTOR DEPENDS–

- (1) On its length (l)
- (2) On its cross sectional area (A)
- (3) On the nature of material

$$\begin{array}{ll} \text{(Resistance)} & R \propto l \quad \text{(Directly prop. to length)} \\ & R \propto \frac{1}{A} \quad \text{(inversely prop to cross-sectional area)} \\ & R \propto \frac{l}{A} \end{array}$$

$$\boxed{R = \rho \frac{l}{A}}$$

Where “ ρ ” (rho) is a proportionality constant known as resistivity of the material of conductor.

11. **Resistivity** (ρ) – the resistance offered by a wire of unit length and unit cross-sectional area is called resistivity.

Its SI unit is $\boxed{\text{m}} \quad \left[\begin{array}{l} \text{Since } R = \rho \frac{l}{A} \\ \rho = \frac{R \cdot A}{l} = \frac{\text{m}^{\Omega}}{\text{m}} \\ \text{SI unit of } \rho \quad \text{m.} \end{array} \right]$

For a material irrespective of length and area, the resistivity is a constant.

Resistivity of a material vary with temperature

Resistivity of an alloy (homogeneous mixture of metals) is generally higher than of its constituent metals. Example Constantan (alloy of Cu & Ni)

Alloys have high resistivity and do not oxidise (burn) readily at high temperature, for this reason they are commonly used in electrical heating devices, like electric iron, heater, toasters etc. For example “Tungsten” as filament of electric bulb.

Resistance in Series– (Maximum Effective Resistance)

Let us take three resistance R_1 , R_2 and R_3 that are connected in series in a circuit.

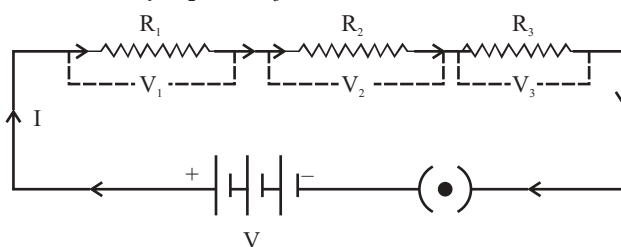

Ohm's law stated

$$V = IR$$

The current (I) flowing through the resistance in series will remain same, where as the potential difference (V) across each resistor will be different.

$$V = IR$$

$$V_1 = IR_1, \quad V_2 = IR_2, \quad V_3 = IR_3$$

$$\text{Total potential difference (V)} = V_1 + V_2 + V_3$$

$$V = IR_1 + IR_2 + IR_3 \quad \left. \vphantom{V = IR_1 + IR_2 + IR_3} \right\} \text{ Putting the value of } V, V_1, V_2 \text{ \& } V_3$$

$$IR = I(R_1 + R_2 + R_3)$$

$$\boxed{R_{\text{eff}} = R_1 + R_2 + R_3}$$

Thus, we conclude that effective Resistance of the several resistors joined in series is equal to the sum of their individual resistance.

Resistance in Parallel (Minimum Effective Resistance)

Let us take three R_1 , R_2 and R_3 , that are connected in parallel in the electric circuit.

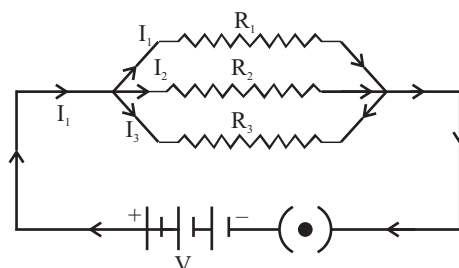

Now,

$$I_1 = \frac{V}{R_1}, I_2 = \frac{V}{R_2}, I_3 = \frac{V}{R_3}$$

Total current (I) = $I_1 + I_2 + I_3$

substitute the value of I_1, I_2, I_3 and I

$$\frac{V}{R} = \frac{V}{R_1} + \frac{V}{R_2} + \frac{V}{R_3}$$

$$\cancel{V} \frac{1}{R} = \cancel{V} \left[\frac{1}{R_1} + \frac{1}{R_2} + \frac{1}{R_3} \right]$$

$$\frac{1}{R_{\text{eff}}} = \frac{1}{R_1} + \frac{1}{R_2} + \frac{1}{R_3}$$

Thus, we conclude that the reciprocal of total effective resistance of the several resistors connected in parallel is equal to the sum of the reciprocals of the individual resistance.

Disadvantage of series connection in on electric circuit :-

1. In series connection if any of the component fail to work, the circuit will break and then none of the component (ex. TV, bulb, fan..) will work.
2. It is not possible to connect a bulb and a heater in series, because they need different value of current to operate properly.

Hence, to overcome this problem we generally use parallel circuit.

Heating effect of Electric Current :

Explanation® Battery or a cell is a source of electrical energy.

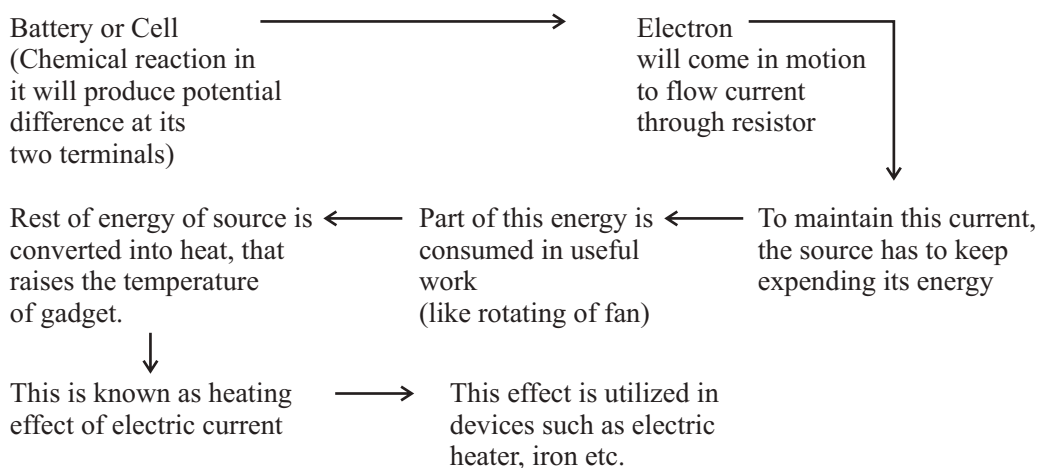

Mathematical Expression :-

Let us suppose that current (I) is flowing through a resistor of resistance (R) for the time (t). The potential difference across the resistance is (V).

$$V = \frac{W}{Q}$$

Work done in moving the charge Q will be

$$W = VQ$$

$$\text{Then power, } P = \frac{W}{t} \quad [\text{Rate of change of work done}]$$

$$= \frac{VQ}{t}$$

$$P = VI \quad \left[\because I = \frac{Q}{t} \right] \quad - (1)$$

Heat energy supplied by the source for time t will be

$$H = P \cdot t \quad \left[\because P = \frac{\text{Energy or Work}}{\text{time}} \right] \quad - (2)$$

Put equation (i) in equation (2)

$$\begin{aligned} H &= VIt \\ &= (IR) It \quad [\quad V = IR \text{ Ohm's Law}] \end{aligned}$$

$$\boxed{H = I^2 R t}$$

This is known as Joule's Law

The law stated that the heat produced in a resistor is

- (i) directly proportional to square of the current(I)
- (ii) directly proportional to resistance (R) for given current
- (iii) directly proportional to time (t) for which current flow through resistor.

Application of Heating Effect of Electric Current :-

- (1) Used in electric iron, toaster, oven, heater etc.
- (2) It is also used in bulb to produce light.

(Filament of bulb is made of strong metal with high melting point such as tungsten (m.pt = 3380°C). This filament can retain as much of the heat generated as possible, to become very hot and emit light)

- (3) It is also used in the "fuse connected in an electric circuit {Fuse a safety device, protect the circuits and appliance by stopping the flow of high current. The wire of fuse is made of an alloy of metals for ex Aluminium Copper, Iron

lead etc. The alloy should be of low m.pt and high resistivity, fuse is always connected in series circuit. When large current flow through the circuit, the temperature of fuse wire will increase. This melts the fuse wire and break the circuit.

“Fuses” used for domestic purposes are rated as 1A, 2A, 3A, 5A, 10A etc. for various operation depending upon the power of appliance using.

Example- let us consider an appliance “electric Iron” which consume 1KW electric power, at 220V

$$P = VI$$

$$I = \frac{P}{V} = \frac{1KW}{220V} = \frac{1000W}{220V}$$

$$I = 4.54A$$

In this case a 5A fuse is required.

Electric Power :- In case of electricity, it is defined as the rate of change electrical energy dissipated or consumed in an electric electrical energy dissipated or consumed in an electric circuit.

$$P = VI$$

$$\text{or } P = I^2R \quad (\because V = IR \text{ Ohm's Law})$$

$$\text{or } P = \frac{V^2}{R} \quad (\because I = \frac{V}{R})$$

$$\text{or } P = \frac{\text{Electrical Energy (E)}}{\text{time (t)}}$$

SI unit of electric power is “Watt” (W).

1 Watt Defined as the power consumed by a device, when 1A of current passes through it at the potential difference of 1V.

$$P = VI$$

$$1 \text{ Watt} = 1 \text{ Volt} \times 1 \text{ Ampere}$$

29 Electrical Energy-

$$P = \frac{E}{t}$$

$$\left[\begin{array}{l} E - \text{Electrical Energy} \\ t - \text{time} \end{array} \right]$$

$$E = P \times t$$

SI unit of electrical energy = Ws or J

Commercial unit of electrical energy = KWh or One unit

$$E = P \times t$$

$$\text{KWh} = 1\text{KW} \times \text{h}$$

$$= 1000\text{W} \times 3600 \text{ s}$$

$$= 36 \times 10^5 \text{Ws}$$

$$= 3.6 \times 10^6 \text{J} \quad (\text{SI unit Ws} = \text{J})$$

$$\text{KWh} = 3.6 \times 10^6 \text{J}$$

$$\text{One horse power} = 746\text{W}$$

EXERCISE

(Question Bank)

Very Short Answers (1 Mark)

1. Define the SI unit of (one mark each)
 - (a) Current
 - (b) Potential Difference
 - (c) Resistance
 - (d) Electric Power
 - (e) Electric Energy (Commercial)
2. What is the conventional direction of flow of current?
3. Define the term resistivity?
4. On what factors does the resistance of a conductor depend?
5. How is the voltmeter and ammeter connected in the electric circuit.
6. Heating effect of current carrying conductor is due to –
(Ans : loss of kinetic energy of electron)
7. Why the filament of bulb has high melting point?
8. How does use of a fuse wire protect electrical appliance?
9. What is the relationship between power, current and potential difference
(Ans : $P = VI$)
10. How many joules are there in 1KWh?

Short Answer (2-3 marks) type Questions

1. Draw a schematic diagram of a circuit consisting of a battery of six cell of 1.5V each, three resistor each of 3 Ω in series and a plug key.
2. State Ohm's law. Draw the graph between V&I?
3. What is joule's Heating effect of current, derive its expression?
4. A wire of length L and R is stretched so that its length's doubled and the area of cross section is halved. How will its
 - (i) Resistance change
 - (ii) Resistivity change.

5. An electrical appliance of power 2KW works at potential difference of 220V. Does it require fuse of 5A, give reason?
6. Calculate the total effective resistance between points A and B

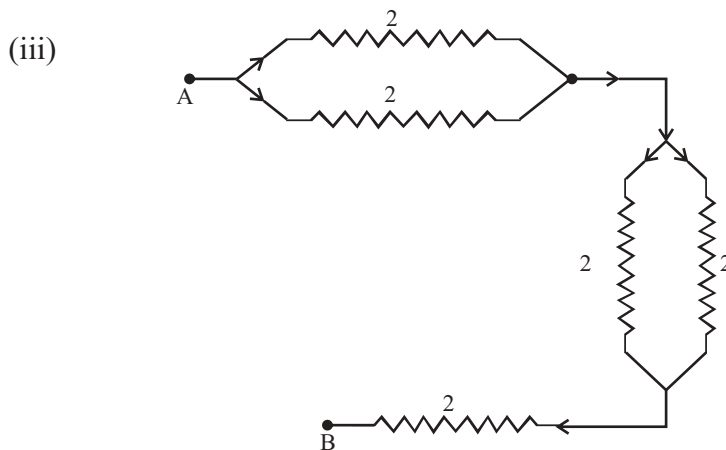
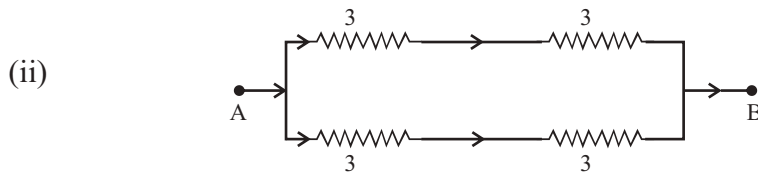
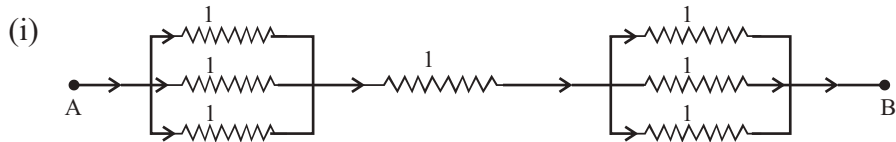

Long Answer (5 Marks) type Questions

1. On what factor the resistance of conductor depends give its mathematical expression. Give the SI unit of resistivity?
Calculate the resistivity of a metal of length 2m at 20°C having the resistance of 20 and diameter 0.3mm?
2. In a circuit below, calculate

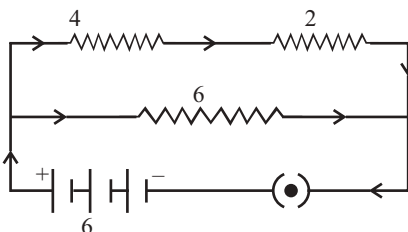

- (1) Calculate total effective resistance
 - (2) The total current through the circuit.
 - (3) Potential difference across 4 Ω and 2 Ω .
3. Three resistance of 2 Ω , 3 Ω and 5 Ω are connected in the electric circuit. Calculate the
- (1) Maximum effective resistance
 - (2) Minimum effective resistance